



**SEPITAM**

ONE STEP SMARTER

---

[www.sepitam.com](http://www.sepitam.com)



SEPITAM  
SFP1G-SM-SX-80KM



TYPE:

## Sepitam-SFP1G-SM-SX-80KM

Sepitam SFP optical transceiver modules support data transmission rates ranging from 1Gbps to 10Gbps. These modules operate at basic and WDM wavelengths and are available in both industrial and non-industrial grades. They are compatible with single-mode and multi-mode optical fibers, covering transmission distances from 20 km to 120 km.



- ▶ TYPE: Sepitam-SFP1G-SM-SX-80KM
- ▶ RoHS Compliant 1.25G 1310/1550nm (1550/1310nm)
- ▶ 80KM Transceiver

## ▶ Description:

The Sepitam-SFP1G-SM-SX-80KM transceivers are high performance, cost effective modules supporting dual data-rate of 1.25Gbps/1.0625Gbps and 80KM transmission distance with SMF.

The transceiver consists of three sections: a DFB laser transmitter, a PIN photodiode integrated with a trans-impedance preamplifier (TIA) and MCU control unit. All modules satisfy class I laser safety requirements.

The transceivers are compatible with SFP Multi-Source Agreement (MSA) and SFF-8472. For further information, please refer to SFP MSA.

## ▶ Properties:

- Dual data-rate of 1.25Gbps/1.063Gbps operation
- 1490nm DFB laser and PIN photo detector for 80KM transmission
- 1310nm FP laser and PIN photo detector for 80KM transmission
- BIDI LC/UPC type pluggable optical interface
- Compliant with SFP MSA and SFF-8472 with simplex LC receptacle
- RoHS compliant and lead-free
- Single +3.3V power supply
- Support Digital Diagnostic Monitoring interface
- Compliant with SFF-8472
- Case operating temperature:
  - Commercial: 0°C to +70°C
  - Extended: -10°C to +80°C
  - Industrial: -40°C to +85°C



## ► Applications:

- Gigabit Ethernet
- Fiber Channel
- Switch to Switch interface
- Switched backplane applications
- Router/Server interface
- Other Optical Links

## ► Functional Diagram:

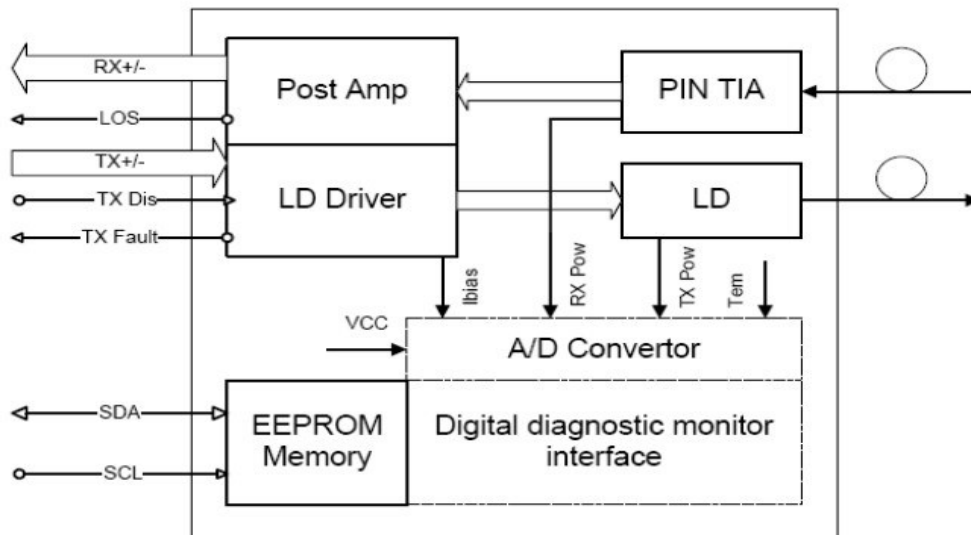



## ▶ Absolute Maximum Ratings:

Parameter	Symbol	Min.	Max.	Unit	Note
Supply Voltage	Vcc	-0.5	4.0	V	–
Storage Temperature	–	-40	85	°C	–
Relative Humidity	–	5	85	%	–

Note: Stress in excess of the maximum absolute ratings can cause permanent damage to the module

## ▶ General Operating Characteristics:

Parameter	Symbol	Min.	Typ	Max.	Unit	Note
Data Rate	–	–	1250	–	Mb/s	–
Supply Voltage	Vcc	3.13	3.3	3.47	V	–
Supply Current	Icc <sub>s</sub>	–	–	220	mA	–
Operating Case Temp.	Tc	0	–	70	°C	–
		-10	–	80	°C	–
		-40	–	85	°C	–



## ► Electrical Input/ Output Characteristics:

### ► Transmitter:

Parameter	Symbol	Min.	Typ	Max.	Unit	Note
Diff. input voltage swing	–	120	–	820	mVpp	1
Tx Disable input	H	VIH	2.0	–	Vcc+0.3	V
	L	VIL	0	–	0.8	
Tx Fault output	H	VOH	2.0	–	Vcc+0.3	V
	L	VOL	0	–	0.8	
Input Diff. Impedance	Zin	–	100	–	Ω	–

### ► Receiver:

Parameter	Symbol	Min.	Type	Max.	Unit	Note
Diff. output voltage swing	–	340	650	800	mVpp	3
Rx LOS Output	H	VOH	2.0	–	Vcc+0.3	V
	L	VOL	0	–	0.8	

- Note 1) TD+/- are internally AC coupled with 100Ω differential termination inside the module.
- Note 2) Tx Fault and Rx LOS are open collector outputs, which should be pulled up with 4.7k to 10kΩ resistors on the host board. Pull up voltage between 2.0V and Vcc+0.3V.
- Note 3) RD+/- outputs are internally AC coupled, and should be terminated with 100Ω (differential) at the user SERDES



## ▶ Optical Characteristics:

### ▶ Transmitter

Parameter	Symbol	Min.	Type	Max.	Unit	Note
Operating Wavelength	λC	1270	1310	1360	nm	-
		1470	1490	1510		
Ave. output power (Enabled)	P <sub>o</sub>	-8	-	-4	dBm	1
Extinction Ratio	ER	9	-	-	dB	1
RMS spectral width	Δλ	-	-	4	nm	-
Rise/Fall time (20%-80%)	Tr/Tf	-	-	0.26	ps	2
Output Eye Mask	Compliant with IEEE802.3 z (class 1 laser safety)					

- Note (1): Measure at 2<sup>23</sup>-1 NRZ PRBS pattern
- Note (2): Transmitter eye mask definition

### ▶ Receiver

Parameter	Symbol	Min.	Type	Max.	Unit	Note
Operating Wavelength	-	1470	1490	1510	nm	-
		1270	1310	1360		
Sensitivity	P <sub>sen</sub>	-	-	-22	dBm	1
Min. overload	P <sub>imax</sub>	-3	-	-	dBm	-
LOS Assert	P <sub>a</sub>	-35	-	-	dBm	-
LOS De-assert	P <sub>d</sub>	-	-	-23	dBm	2
LOS Hysteresis	P <sub>d</sub> -P <sub>a</sub>	0.5	-	6	dB	-

- Note (1): Measured with Light source 1490nm(1310nm), ER=9dB; BER =<10<sup>-12</sup> @PRBS=2<sup>23</sup>-1 NRZ.
- Note (2): When LOS de-asserted, the RX data+/- output is signal output.





## Pin Definitions and Functions:

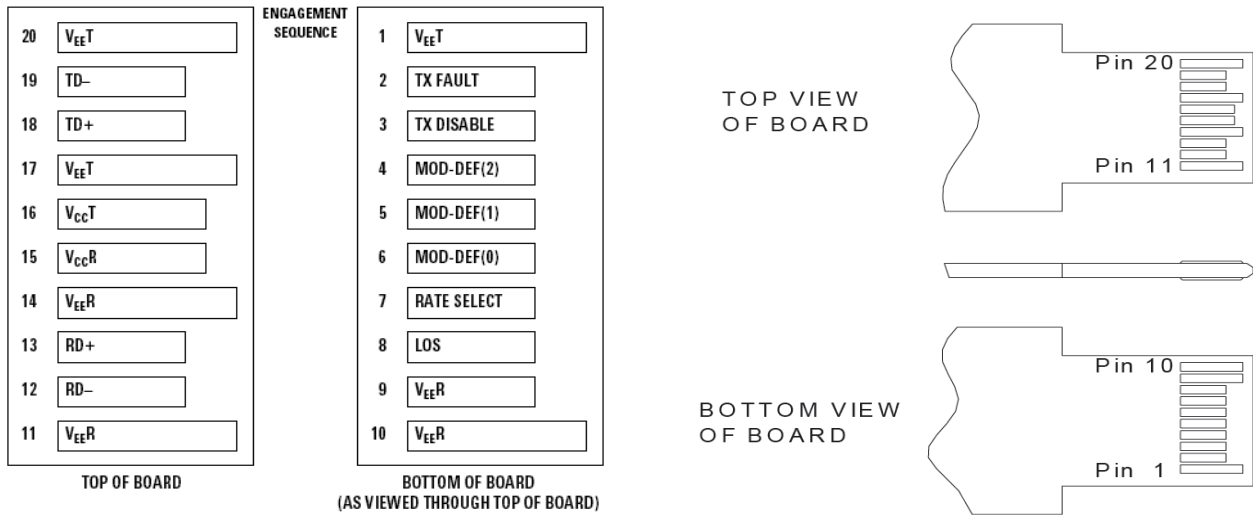

PIN#	Name	Function	Notes
1	VeeT	Tx ground	-
2	Tx Fault	Tx fault indication, Open Collector Output, active "H"	1
3	Tx Disable	LVTTL Input, internal pull-up, Tx disabled on "H"	2
4	MOD-DEF2	2 wire serial interface data input/output (SDA)	3
5	MOD-DEF1	2 wire serial interface clock input (SCL)	3
6	MOD-DEF0	Model present indication	3
7	Rate select	No connection	-
8	LOS	Rx loss of signal, Open Collector Output, active "H"	4
9	VeeR	Rx ground	-
10	VeeR	Rx ground	-



PIN#	Name	Function	Notes
11	VeeR	Rx ground	-
12	RD-	Inverse received data out	5
13	RD+	Received data out	5
14	VeeR	Rx ground	-
15	VccR	Rx power supply	-
16	VccT	Tx power supply	-
17	VeeT	Tx ground	-
18	TD+	Transmit data in	6
19	TD-	Inverse transmit data in	6
20	VeeT	Tx ground	-

- Note 1) When high, this output indicates a laser fault of some kind. Low indicates normal operation. And should be pulled up with a 4.7 – 10K $\Omega$  resistor on the host board.
- Note 2) TX disable is an input that is used to shut down the transmitter optical output. It is pulled up within the module with a 4.7 – 10K $\Omega$  resistor. Its states are:
  - Low (0 – 0.8V): Transmitter on (>0.8, < 2.0V): Undefined
  - High (2.0V~Vcc+0.3V): Transmitter Disabled Open: Transmitter Disabled
- Note 3) Mod-Def 0,1,2. These are the module definition pins. They should be pulled up with a 4.7K – 10K $\Omega$  resistor on the host board. The pull-up voltage shall be VccT or VccR.
  - Mod-Def 0 has been grounded by the module to indicate that the module is present
  - Mod-Def 1 is the clock line of two wire serial interface for serial ID
  - Mod-Def 2 is the data line of two wire serial interface for serial ID
- Note 4) When high, this output indicates loss of signal (LOS). Low indicates normal operation.
- Note 5) RD+/-: These are the differential receiver outputs. They are AC coupled 100 $\Omega$  differential lines which should be terminated with 100 $\Omega$  (differential) at the user SERDES. The AC coupling is done inside the module and is thus not required on the host board.
- Note 6) TD+/-: These are the differential transmitter inputs. They are AC-coupled, differential lines with 100 $\Omega$  differential termination inside the module. The AC coupling is done inside the module and is thus not required on the host board.



## ▶ Diagnostics:

### ▶ Diagnostics Specification

Parameter	Range	Unit	Accuracy	Calibration
Temperature	0 to +70 , -40 to +85	°C	±3°C	Internal/ External
Voltage	3.0 to 3.6	V	±3%	Internal/ External
Bias Current	2 to 80	mA	±10%	Internal/ External
TX Power	-11 to -1	dBm	±3dB	Internal/ External
RX Power	-25 to 0	dBm	±3dB	Internal/ External

### ▶ Typical Interface Circuit

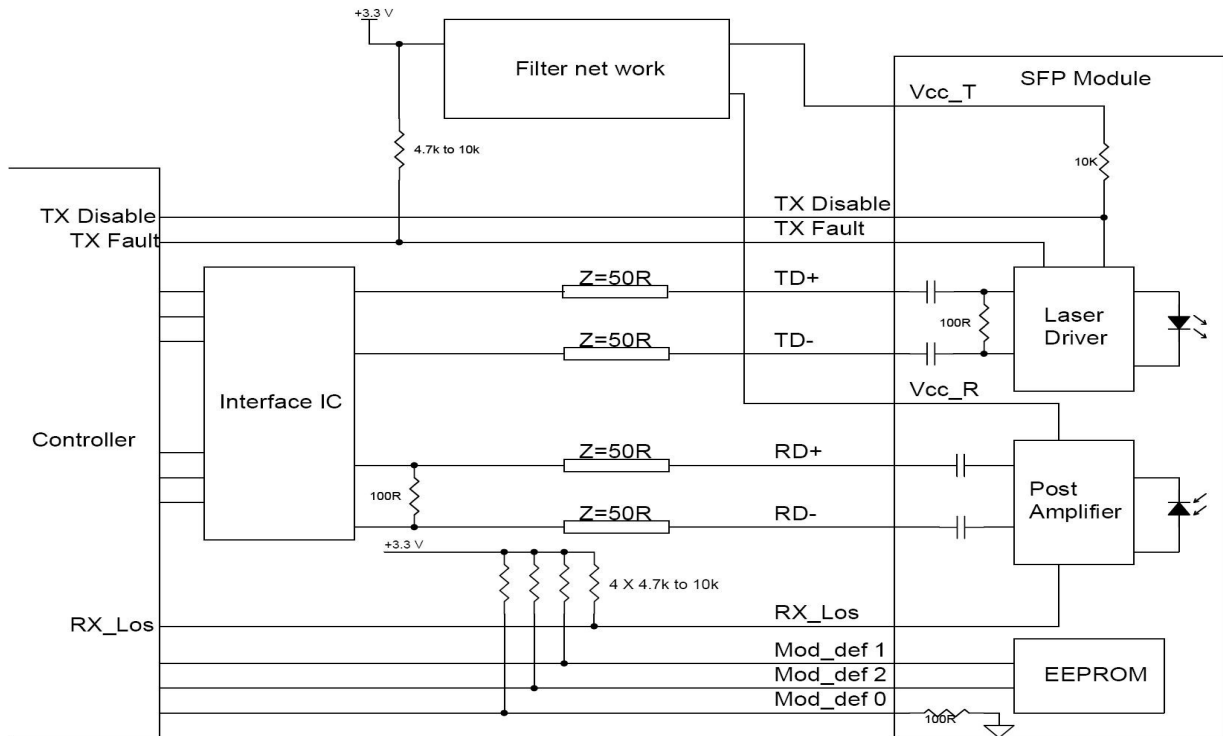

# Technical Specification of Sepitam-SFP1G-SM-SX-80KM



[www.sepitam.com](http://www.sepitam.com)

[Info@sepitam.com](mailto:Info@sepitam.com)